

## H Type

With the *H Type*, Brompton is launching its first new handlebar configuration for seven years. It joins Brompton's existing offering of three handlebar styles – the *M*, *S* and *P* Types.

The *H Type* has been developed in response to requests from taller riders and from those wanting a markedly more upright riding position. The height of the grips from the ground has been raised by 60mm compared to the classic *M Type*; forward reach to the grips from the saddle increases by around 13mm.

This additional height and reach has been achieved by spacing the handlebar hinge 30mm further away from the headset [see diagrams overleaf]. While this means that the hinge protrudes further from the bike than on other



models, the highest point on the folded bike remains the saddle, so the *H Type* fits into all existing transportation bags and covers.

The weight increase over an *M Type* is approximately 100g (varying slightly depending on the gearing option chosen, as the cables necessarily vary). Pricing will be the same as the other model types.

The *H Type* is for those who like to travel with unhurried style, taking in the journey along the way. It will certainly extend the Brompton's appeal to the tallest riders but will also appeal to all those seeking an upright riding position, with good visibility.

**PRODUCT LAUNCHES 2012**

**BROMPTON**

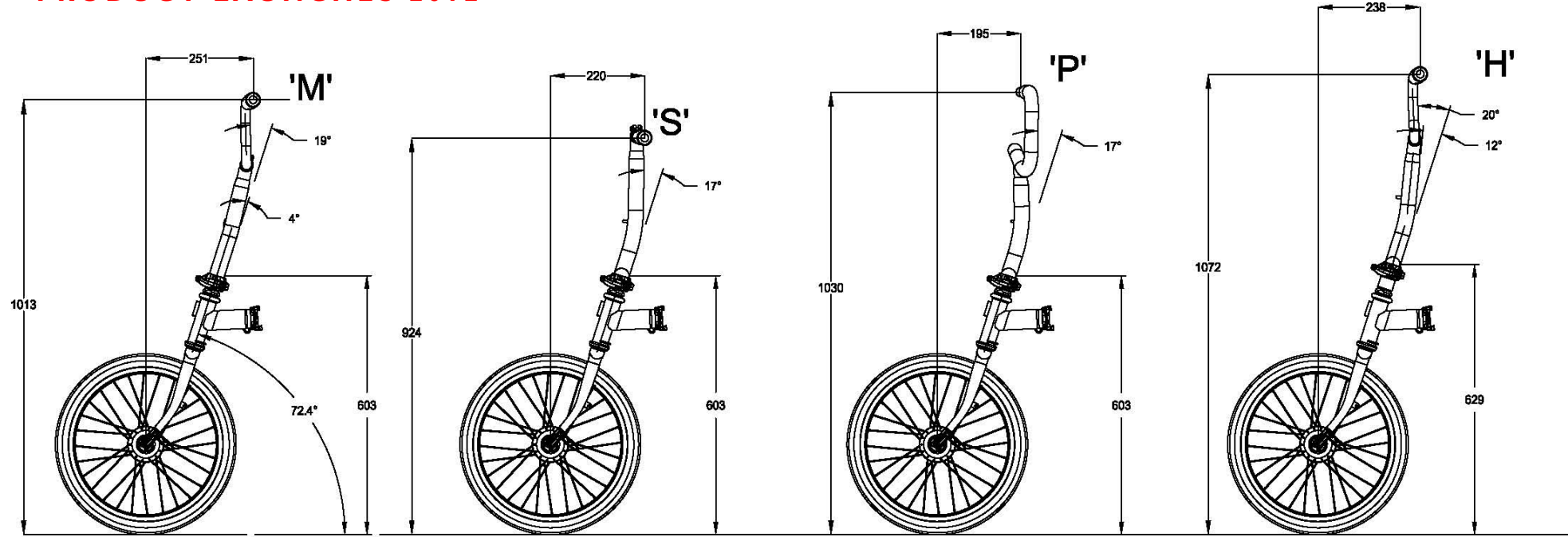

*How the four handlebar models compare from the side and the front*

